

ST-DRY® & ST-DRY HP Series Adapters

ADAPTERS

The ST Series adapters feature an integral self-sealing design that ensures a watertight, environmentally sealed fiber termination. The ST Series assembly forms a watertight connection that completely protects the fiber optic cable from water, humidity, vapors, gases, chemicals and invasion by particulate that can interfere with transmission and degrade the performance of the optical fiber. The ST-DRY® adapter is fabricated from nickel-plated brass, and the ST-DRY HP is fabricated from 316 series stainless steel. ST Series adapters are available with or without a bulkhead seal. Adapters with a bulkhead seal can be utilized as feedthroughs for bulkheads from .100 in. to .225 in. (2.54 mm to 5.71 mm) thick. When used as a feedthrough one side must remain connected to maintain seal integrity.

FEATURES & BENEFITS

Compatibility—Available with or without a bulkhead seal; works with both single and multi-mode fiber

Environmentally Sealed—No signal degradation.

- Effective sealing action eliminates damage from moisture or particulate
- Tested up to 500 mate/demate cycles

Temperature and Humidity Resistant—Clarity of signal. Tested from -67°F to 185°F (-55°C to 85°C) and subjected to stringent heat/humidity with 0.5dB maximum insertion loss

Waterproof—No water penetration to effect signal; tested to 1000 psig (688 bar) with no evidence of leakage

SPECIFICATIONS

- Ferrules and alignment sleeves are precision-machined zirconia
- Made from high quality, corrosion-resistant materials; ST-DRY is nickel plated brass; ST-DRY HP is 316 series stainless steel
- Typical light loss is less than 0.5dB

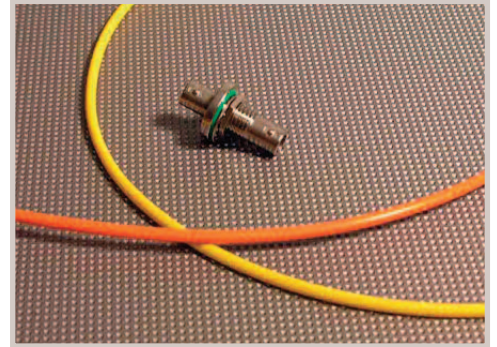

APPLICATIONS

- Aerospace
- Chemical processing
- Defense
- Industrial
- Oil and gas
- Pharmaceutical production
- Security
- Telecommunication

LANCER
SYSTEMS

ST-DRY® Adapter

- Minimum bulkhead thickness – .100 in. (2.54 mm)
- Maximum bulkhead thickness – .225 in. (5.71 mm)

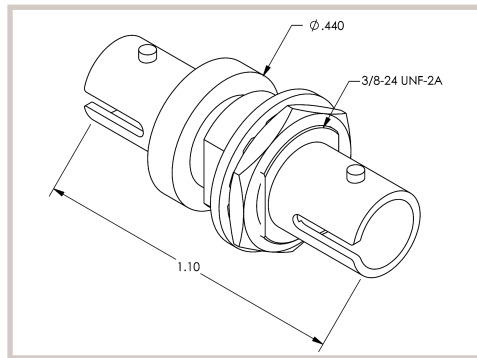
**ST-DRY® HP Adapter with bulkhead seal**

- Minimum bulkhead thickness – .100 in. (2.54 mm)
- Maximum bulkhead thickness – .225 in. (5.71 mm)

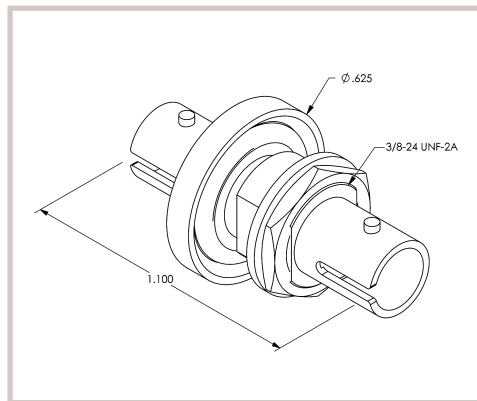
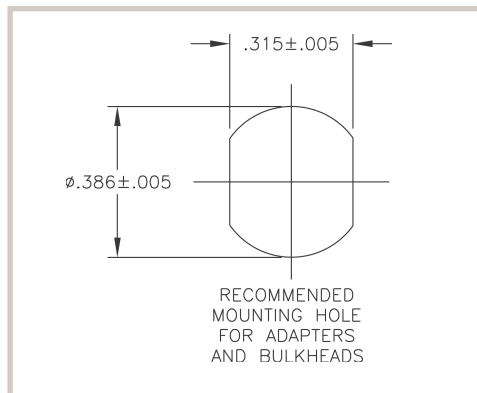
**Mounting Diagram****ORDERING INFORMATION**

500-AST- S- 01-000

B Bulkhead Seal
N No Bulkhead

Material Type

B Brass Nickel Plate
S Stainless Steel

Meets dimensional requirements of MIL-C-83522/16&17

Statements and recommendations in this publication are based on our experience and knowledge of typical applications for this product and shall not constitute a guarantee or warranty of performance nor a modification or alteration of our standard product warranty which shall be applicable to such products. To ensure hermeticity and environmentally sealed connections that utilize a Lancer Systems adapter and/or feedthrough it is IMPORTANT that you use only connectivity products from Lancer Systems. The performance of the connector within a given assembly can produce varying results.

www.Lancer-Systems.com
Sales@Lancer-Systems.com

LANCER
 SYSTEMS