

# ST-DRY® & ST-DRY HP Series Connectors

## CONNECTORS

The ST Series connectors combine a bayonet twist-lock connection with a unique self-sealing design to provide a watertight, environmentally and hermetically sealed fiber termination when used with an ST Series adapter. The termination is completely protected from wet environments and particulate that can irreversibly degrade optical fiber. The ST-DRY® is fabricated from nickel-plated brass, and the ST-DRY HP is fabricated from 316 series stainless steel. The ferrules and alignment sleeves are made of precision-machined zirconia. The ST-DRY HP Series is intended for use in environments where the assemblies are likely to be submerged in water or subjected to rain, ice, high humidity or temperatures from -67°F to 185°F (-55°C to 85°C). ST Series connectors have passed stringent immersion and heat/humidity tests with minimal light loss.

## FEATURES & BENEFITS

**Compatibility**—Universal bayonet twist-lock connection; works with both single and multi-mode fiber

**Environmentally Sealed**—No signal degradation

- Effective sealing action eliminates damage from moisture or particulate
- Tested up to 500 mate/demate cycles

**Temperature and Humidity Resistance**—Clarity of signal. Tested from -67°F to 185°F (-55°C to 85°C) and subjected to stringent heat/humidity with 0.5dB maximum insertion loss

**Waterproof**—No water penetration to effect signal. Tested to 1000 psig (688 bar) with no evidence of leakage

## SPECIFICATIONS

- Ferrules and alignment sleeves are precision-machined zirconia
- Made from high quality corrosion resistant materials; ST-DRY is nickel-plated brass; ST-DRY HP is 316 series stainless steel
- Typical light loss is less than 0.5dB

## APPLICATIONS

- Aerospace
- Chemical processing
- Defense
- Industrial
- Oil and gas
- Pharmaceutical production
- Security
- Telecommunications

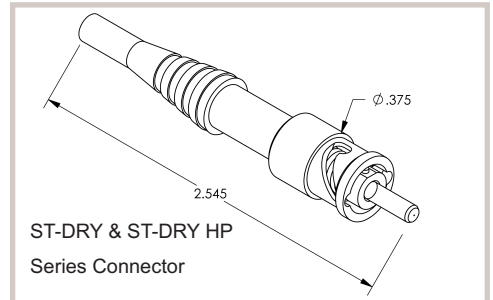
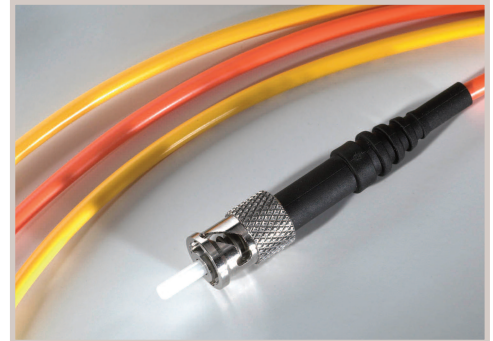

## ORDERING INFORMATION

500-CST- -N01-000

### Fiber Type

- 0 None
- 1 9/125 μm
- 2 50/125 μm
- 3 62.5/125 μm
- 4 50/170 μm
- 5 400/430 μm
- 6 400/440 μm
- 7 910/1000 μm
- 8 300/330 μm
- 9 9/80 μm
- C Custom

### Material Type

- B Brass Nickel Plate
- S Stainless Steel

Statements and recommendations in this publication are based on our experience and knowledge of typical applications for this product and shall not constitute a guarantee or warranty of performance nor a modification or alteration of our standard product warranty which shall be applicable to such products. To ensure hermeticity and environmentally sealed connections that utilize a Lancer Systems adapter and/or feedthrough it is IMPORTANT that you use only connectivity products from Lancer Systems. The performance of the connector within a given assembly can produce varying results.

www.lancer-systems.com  
sales@lancer-systems.com

