

# ST-DRY® & ST-DRY® HP Connectors

## Termination Instructions

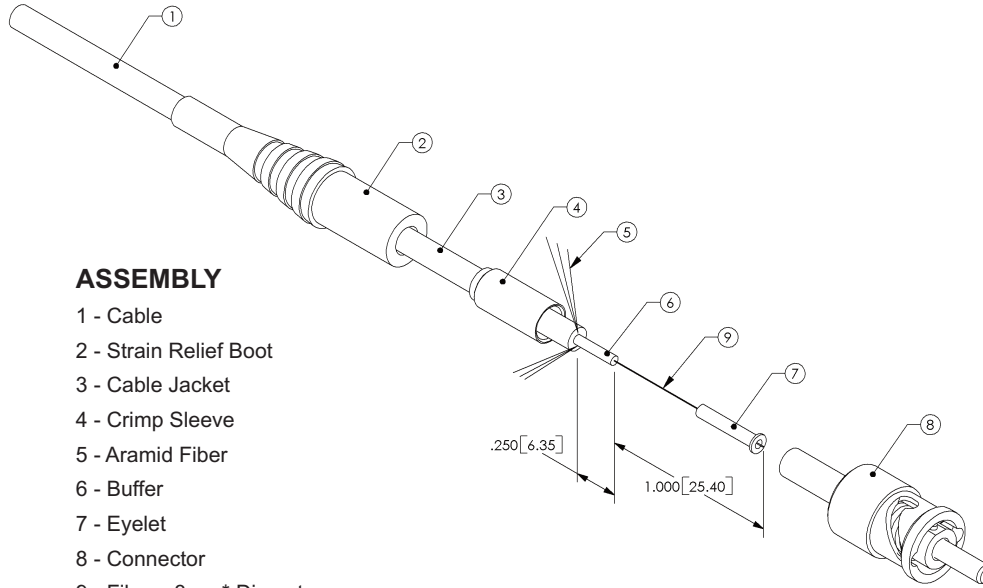

### ASSEMBLY

- 1 - Cable
- 2 - Strain Relief Boot
- 3 - Cable Jacket
- 4 - Crimp Sleeve
- 5 - Aramid Fiber
- 6 - Buffer
- 7 - Eyelet
- 8 - Connector
- 9 - Fiber - 3mm\* Diameter

\* For other fiber diameters contact Lancer Systems technical support for termination instructions

### PARTS SUPPLIED

- ST-DRY or ST-DRY HP Connector
- Crimp Sleeve
- Eyelet
- Strain Relief Boot

### ADDITIONAL NEEDED

- Crimp Pliers with .128" (3.25mm) and .178" (4.51mm) Hex Crimp Tool
- Epoxy Curing Oven (120°C)
- Epoxy Dispensing Needle
- Fiber Cleave Tool
- Fiber Optic Cable
- Fiber Polishing Equipment
- Isopropyl Alcohol
- Lint-free Wipes
- Mastic Adhesive
- Jacket Strippers
- Tra-Con F123 Epoxy

### PROCEDURE

1. Cut the fiber to the desired length.
2. Slide strain relief boot over cable. (see diagram)
3. Slide crimp sleeve over cable. (see diagram)
4. Strip cable jacket 1.25" (31.75mm).
5. Gather the aramid fiber together and ensure the length is 1.0" (25.4mm) from outer jacket.
6. Thread the eyelet over the fiber and tuck inside outer jacket.
7. Strip buffer from fiber .25" (6.35mm) from outer jacket cable.
8. Clean residue from fiber using a lint-free wipe and alcohol.
9. Mix Tra-Bond according to manufacturers instructions.
10. Inject epoxy into the ferrule using a dispensing needle until a small bead appears on the ferrule tip.
11. Carefully insert fiber into the ferrule until the cable is seated inside of the connector, with the ferrule stem over the aramid fiber and outer cable jacket.
12. Verify the aramid is evenly distributed around connector stem.
13. Place .128" (3.25mm) crimping tool against the back of the connector head. Crimp connector. The end of the connector should be slightly flared.
14. Slide the crimp sleeve and aramid fiber over the top of the crimped stem.
15. Crimp the sleeve using the .178" (4.51mm) hex crimps.
16. Cure epoxy in an oven for 5 minutes at 120°C
17. Cleave fiber using the cleaving tool.
18. Polish fiber and ferrule. Clean using lint-free wipe and alcohol.
19. Apply mastic adhesive over the bottom half of the crimp sleeve and .25" (6.35mm) of the cable. Slowly twist the strain relief boot up and over the mastic until the boot is fully seated. Cure per manufacturer's instructions.
20. Perform insertion loss test on completed cable.